

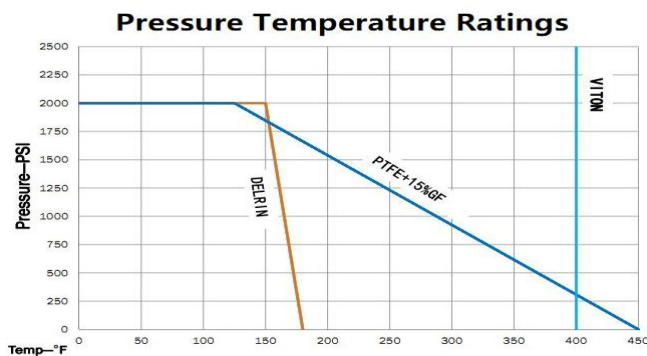

# TOP OILFIELD PRODUCTS

## DUCTILE IRON BALL VALVE

### TBAD-FP SERIES

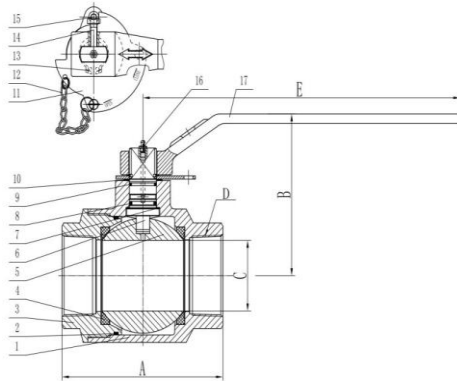

#### Features:

- 2000 W.O.G. (FULL PORT)
- DUCTILE IRON BODY
- BLOW OUT PROOF STEM
- (1" 2") RPTFE / (3" 4") DELRIN SEAT
- INSPECTION AND TEST: API598
- THREADS CONFORM TO ASME B1.20.1(NPT)
- NACE MR-01-75

#### Parts & Materials

NO.	Description	Material
1	BODY	ASTM A395 DI
2	BODY SEAL	VITON
3	ADAPTER	ASTM A395 DI
4	SEATS	PTFE + 15%GF / DELRIN
5	BALL	SS420
6	STEM	ASTM A276 420
7	THRUST BEARING	PTFE
8	STEM SEAL	VITON
9	STEM SEAL	VITON
10	STEM BEARING	PTFE
11	STOP PLATE	STEEL PLATE
12	PIN WITH CHAIN	STAINLESS STEEL
13	RETAINER RING	SPRING STEEL
14	STOP PIN	SPRING STEEL
15	HEXAGON BOLTS	CARBON STEEL
16	GREASE ZERK	CARBON STEEL
17	HANDLE	DUCTILE IRON

#### Dimensions(in)

Size	Part #	Port	Pressure	Weight (lbs)	A	B	C	D	E
1"	TBAD06R20F	FP	2000	4.25	4.02	3.39	1.00	11.5NPT	6.57
2"	TBAD09R20F	FP	2000	17.97	6.00	5.51	2.02	11.5NPT	10.00
2-1/2"	TBAD10K20F	FP	2000	28.99	7.00	6.35	2.56	8NPT	15.00
3"	TBAD11L20F	FP	2000	42.33	8.74	6.85	2.99	8NPT	15.00
4"	TBAD12L20F	FP	2000	52.69	9.40	6.77	3.94	8NPT	29.53

#### EES Enduro-Bond™ Features

- Protects over wide temperature range.
- Resists direct burial soil stress.
- Excellent chemical resistance.
- Suitable for elevated temperature in the presence of H<sub>2</sub>S, CO<sub>2</sub>, CH<sub>4</sub>, crude oil and brine.
- Domestically assembled with global components and tested to API certifications.
- High adhesion and toughness.
- Resists cavitation and cathodic disbondment

Address: 9239 Alberene Dr. Houston Texas 77074  
 Tel: 832-480-3855, e-mail: sales@topoilfieldproducts.com