

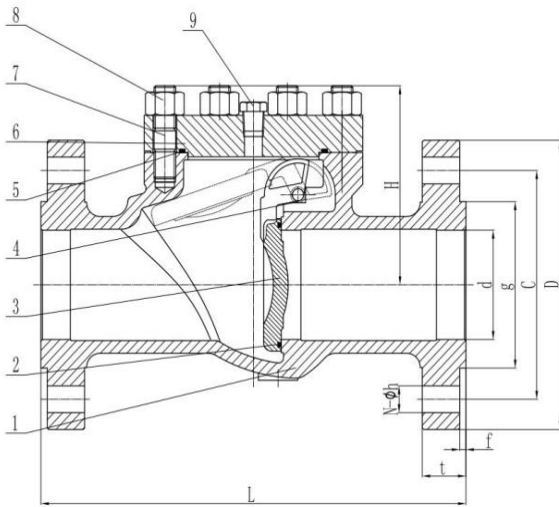

TOP OILFIELD PRODUCTS

FLANGED END CHECK VALVE

TFKA CLASS 150 SERIES



Features:

- WCB Cast Body and Adapter
- Integral or replaceable seat available
- Valves Designed to API6D ASME B16.34 standard
- Valves Flanges ASME B16.5 standard
- 316SS disc standard
- Bolted bonnet with tap is standard
- NACE MR0175
- 6 inserted pin spring type

Specifications

NOMINAL PRESSURE	285psi	2.0Mpa
SHELL STRENGTH (WATER)	450psi	3.0Mpa
SEALING TEST (WATER)	315psi	2.2Mpa
AIR SEAT PING (AIR)	80.8psi	0.55Mpa

Carbon Steel
A216 WCB
ASME B16.34 Ratings
Material Limits

Pressure Temperature Ratings

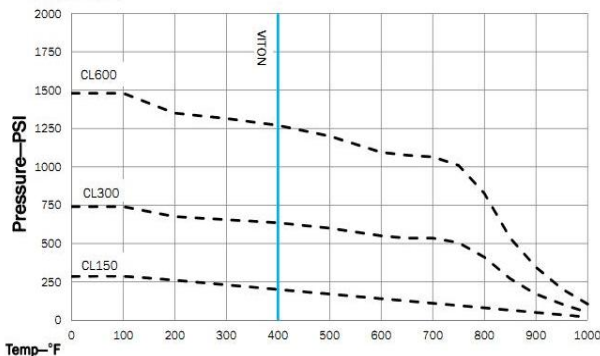

Parts & Materials

NO.	Description	Material
1	BODY	ASTM A216 WCB
2	SEAT	VITON
3	DISC	ASTM A351 CF8M
4	DISC SEAT	SS316
5	BONNET SEAL	VITON
6	BONNET	ASTM A193 WCB
7	STUD	ASTM A193 B7
8	NUT	ASTM A194 2H
9	BONNET SCREW	CARBON STEEL

Dimensions(in)

NPS	L	D	C	g	d	N	h	t	f	H
2"	8.00	6.00	4.75	3.62	2.06	4	0.75	0.63	0.06	4.41
3"	9.50	7.50	6.00	5.00	3.13	4	0.75	0.75	0.06	5.69
4"	11.50	9.00	7.50	6.18	4.06	8	0.75	0.94	0.06	6.42
6"	14.00	10.98	9.50	8.50	5.91	8	0.88	1.00	0.06	7.19

Address: 9239 Alberene Dr. Houston Texas 77074

Tel: 832-480-3855, e-mail: sales@topoilfieldproducts.com