

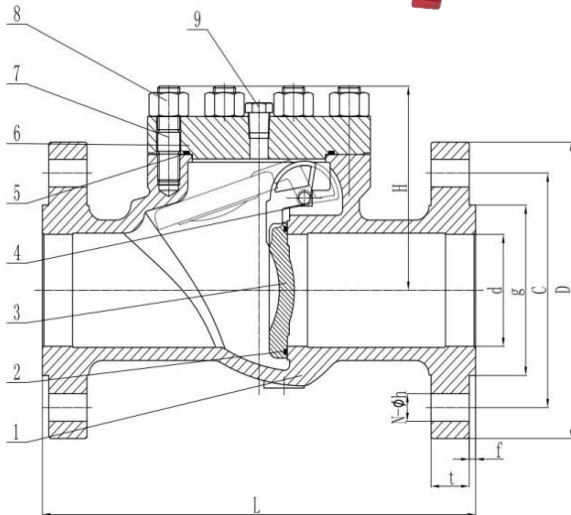

TOP OILFIELD PRODUCTS

FLANGED END CHECK VALVE

TFKA CLASS 600 SERIES



Features:

- WCB Cast Body and Adapter
- Integral or replaceable seat available
- Valves Designed to API 6D ASME B16.34 standard
- Valves Flanges ASME B16.5 standard
- 316SS disc standard
- Bolted bonnet with tap is standard
- NACE MR0175
- 6 inserted pin spring type

Specifications

NOMINAL PRESSURE	1480psi	10.2Mpa
SHELL STRENGTH (WATER)	2225psi	15.3Mpa
SEALING TEST (WATER)	1630psi	11.5Mpa
AIR SEAT PING (AIR)	80.8psi	0.55Mpa

Parts & Materials

NO.	Description	Material
1	BODY	ASTM A216 WCB
2	SEAT	VITON
3	DISC	ASTM A351 CF8M
4	DISC SEAT	STAINLESS ATEEL
5	BONNET SEAL	VITON
6	BONNET	ASTM A216 WCB
7	STUD	ASTM A193 B7
8	NUT	ASTM A194 2H
9	BONNET SCREW	CARBON STEEL

Carbon Steel
A216 WCB
ASME B16.34 Ratings
Material Limits

Pressure Temperature Ratings

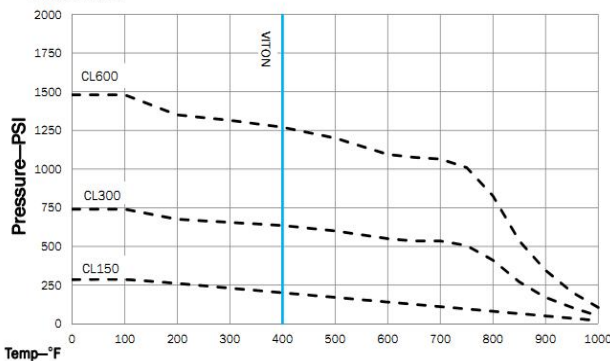

Dimensions(in)

NPS	L	D	C	g	d	N	h	t	f	H
2"	11.50	6.50	5.00	3.62	2.06	8	0.75	1.00	0.25	5.04
3"	14.00	8.25	6.63	5.00	3.13	8	0.88	1.25	0.25	6.48
4"	17.00	10.75	8.50	6.18	4.06	8	1.00	1.50	0.25	7.40
6"	22.00	14.00	11.50	8.50	6.00	12	1.13	1.88	0.25	8.70

Address: 9239 Alberene Dr. Houston Texas 77074

Tel: 832-480-3855, e-mail: sales@topoilfieldproducts.com