

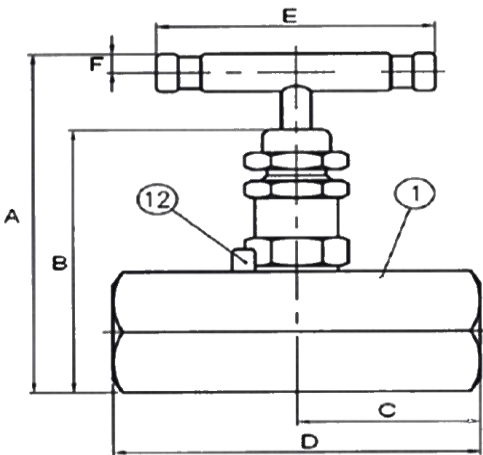

# TOP OILFIELD PRODUCTS

## TNCPV 6000 (F X F)

### CARBON STEEL NEEDLE VALVE

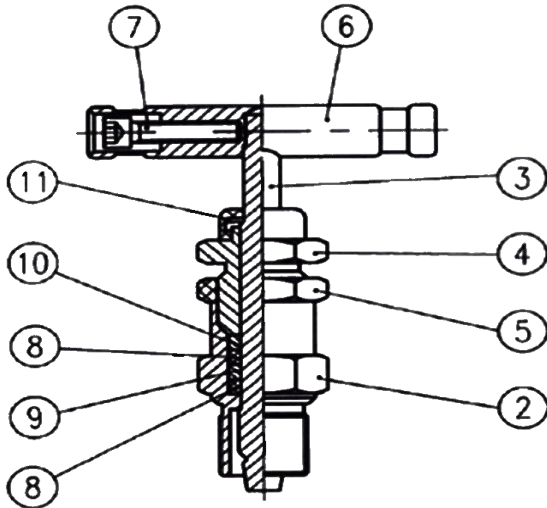

#### Specifications:

- RATED TO 6000 PSI (T TYPE)
- CARBON STEEL CONSTRUCTION
- TEFLON PACKING
- WORKING TEMPERATURE (-20 DEG. F TO 200 DEG. F)
- THREADS CONFORM TO ASME B1.20.1
- NACE MR0175

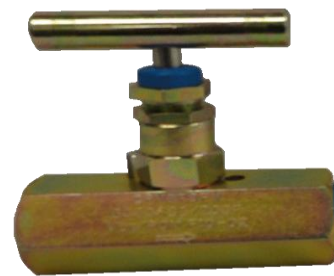

#### Parts & Materials

NO.	Description	Materials
1	BODY	CARBON STEEL
2	BONNET	CARBON STEEL
3	STEM	SS304
4	PACKING NUT	CARBON STEEL
5	FIXING SCREW	CARBON STEEL
6	HANDLE	CARBON STEEL
7	HANDLE FIXING SCREW	CARBON STEEL
8	PACKING	VITON
9	BACK UP RING	TEFLON
10	BACK UP RING	TEFLON
11	DUST CAP	NBR
12	BONNET LOCK PIN	SS303

#### Dimensions(in)

NPS	Part #	Description	A	B	C	D	E	F
1/4"	TNCPV4F4FV	CARBON STEEL (F x F) 6000PSI	3.54	2.74	1.47	2.95	2.24	0.19
1/2"	TNCPV8F8FV	CARBON STEEL (F x F) 6000PSI	3.54	2.74	1.47	2.95	2.24	0.19
3/4"	*TNCPV12F12FV	CARBON STEEL (F x F) 6000PSI	3.54	2.74	1.47	2.95	2.24	0.19
1"	TNCPV16F16FV	CARBON STEEL (F x F) 6000PSI	3.54	2.74	1.47	2.95	2.24	0.19

Due to continuous improvements, design may change without prior notice.

\*Asterisked sizes are available from the manufacture upon request. (90+day lead time)

Address:9239 Alberene Road Houston Texas 77074  
Tel:832-480-3855 E-Mail: Sales@topoilfieldproducts.com