

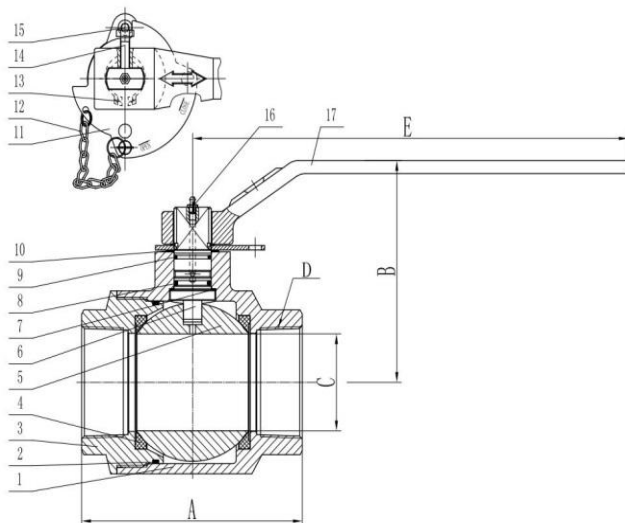

TOP OILFIELD PRODUCTS

DUCTILE IRON BALL VALVE

TBAD-M SERIES

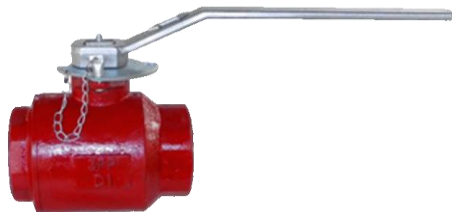

Pressure Temperature Ratings

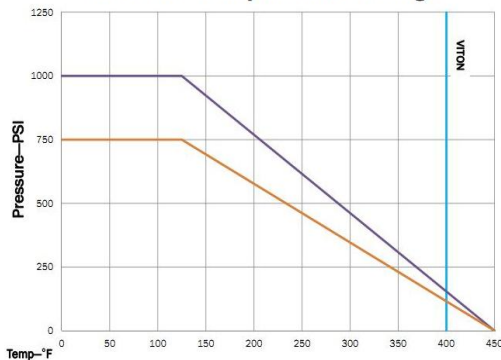

Features:

- 750/1000 W.O.G.
- DUCTILE IRON BODY
- BLOW OUT PROOF STEM
- INSPECTION AND TEST:API598
- THREADS CONFORM TO ASME B1.20.1 (NPT)
- NACE MR-01-75

Parts & Materials

NO.	Description	Material
1	BODY	ASTM A395 DI
2	BODY SEAL	VITON
3	ADAPTER	ASTM A395 DI
4	SEATS	PTFE + 15%GF / DELRIN
5	BALL	SS420
6	STEM	ASTM A276 420
7	THRUST BEARING	PTFE
8	STEM SEAL	VITON
9	STEM SEAL	VITON
10	STEM BEARING	PTFE
11	STOP PLATE	STEEL PLATE
12	PIN WITH CHAIN	STAINLESS STEEL
13	RETAINER RING	SPRING STEEL
14	STOP PIN	SPRING STEEL
15	HEXAGON BOLTS	CARBON STEEL
16	GREASE ZERK	CARBON STEEL
17	HANDLE	DUCTILE IRON

Dimensions(in)

Size	Part #	Port	Pressure	Weight(lbs)	A	B	C	D	E
2"	TBADM09R7	RP	750	11.29	5.25	5.59	1.50	11.5NPT	8.5
	TBADM09R10		1000						
	TBADM09R7F	FP	750	17.97					
	TBADM09R10F		1000						
3"	TBADM11R7	RP	750	19.44	7.31	5.53	2.00	8NPT	10
	TBADM11R10		1000						
	TBADM11R7F	FP	750	28.88					
	TBADM11R10F		1000						
4"	TBADM12R7	RP	750	35.16	8.75	6.85	2.99	8NPT	15
	TBADM12R10		1000						

Address: 9239 Alberene Dr. Houston Texas 77074
 Tel: 832-480-3855, e-mail: sales@topoilfieldproducts.com