



TOP OILFIELD PRODUCTS

NOTCHED WAFER BUTTERFLY "SHORT NECK"

200PSI Nickel Disc/Buna Seat

TWW-NBL2SD-Series

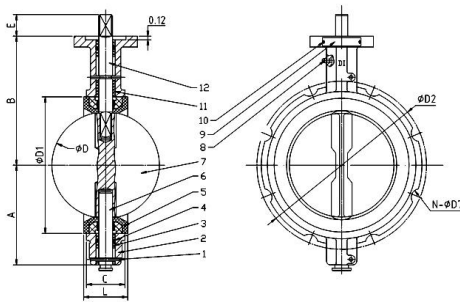
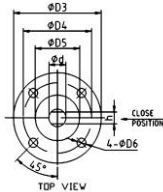

Standard Features

- Ductile Iron Body
- **Nickel Plated Ductile Iron Disc**
- Buna Seat
- ISO 5211 Mounting Pad
- **Pinless Double Shaft**, Double "D"
- Lever Handle
- Test Standard API 598
- Flange ANSI B16.1 Class 125
- Face To Face API 609

Parts & Materials

NO.	Description	Material
1	Roll Pin	Carbon Steel/ Zinc
2	Body	Ductile Iron
3	Short Bushing	F4
4	O-Ring	Buna
5	Seat	Buna
6	Lower Stem	Carbon Steel/ Zinc
7	Disc	Nickel Plated DI
8	Grease Fitting	Carbon Steel/ Zinc
9	Name Plate	Aluminum
10	Plate Rivet	Aluminum
11	Long Bushing	F4
12	Upper Stem	Carbon Steel/ Zinc

Working Pressure/Temp		
Normal Pressure	200 PSI	1.4 Mpa
NBR	Neg. 20°C	90°C

Test Pressures		
Shell Test	300 PSI	2.1 Mpa
Seat Test	220 PSI	1.6 Mpa

NPS	D	D2	N	D7	D1	D3	D4	D5	D6	d	A	B	C	L	h	E	ft. lb	wt.
2"	2.08	4.75	4	0.75	3.00	3.03	1.97	1.61	0.28	0.50	3.15	3.94	1.65	1.81	0.35	1.10	10.32	8.16
3"	3.10	6.00	4	0.75	4.09	3.03	1.97	1.61	0.28	0.50	3.74	4.88	1.78	1.93	0.35	1.10	19.98	11.02
4"	4.10	7.50	8	0.75	5.31	3.62	2.76	2.17	0.39	0.62	4.49	5.98	2.05	2.18	0.44	1.10	36.65	11.24
5"	4.86	8.50	8	0.88	6.26	3.62	2.76	2.17	0.39	0.74	5.00	5.98	2.14	2.31	0.50	1.10	62.47	17.42
6"	6.13	9.50	8	0.88	7.42	3.62	2.76	2.17	0.39	0.74	5.47	6.50	2.20	2.33	0.50	1.10	96.88	18.96
8"	7.97	11.75	8	0.88	9.37	4.92	4.02	2.76	0.47	0.87	6.89	8.07	2.39	2.52	0.63	1.50	175.02	32.63
10"	9.86	14.25	12	1.00	11.51	4.92	4.02	2.76	0.47	1.12	7.99	9.98	2.58	2.83	0.81	1.57	309.3	50.71
12"	11.87	17.00	12	1.00	13.55	5.51	4.02	2.76	0.47	1.24	9.53	10.91	3.03	3.19	0.87	1.57	491.60	80.03

EES Enduro-Bond™ Features

- Protects over wide temperature range.
- Resists direct burial soil stress.
- Excellent chemical resistance.
- Suitable for elevated temperature in the presence of H₂S, CO₂, CH₄, crude oil and brine.
- Domestically assembled with global components and tested to API certifications.
- High adhesion and toughness.
- Resists cavitation and cathodic disbondment

Address: 9239 Alberene Dr. Houston Texas 77074

Tel: 832-480-3855, e-mail: sales@topoilfieldproducts.com